

PEDANE STEEL-TECH

istruzioni d'assemblaggio

MATERIALE DI COSTRUZIONE acciaio 39NiCrMo3, alu. 7075 e inox
LAVORAZIONI fresatura e tornitura dal pieno
TRATTAMENTI SUPERFICIALI ossid. anod. colore e trattamento QPQ



1.

Assemblare i grani M4 sulle pedane.
Utilizzare frenafilletti (Loctite 243).
Coppia di serraggio 3,5 Nm.

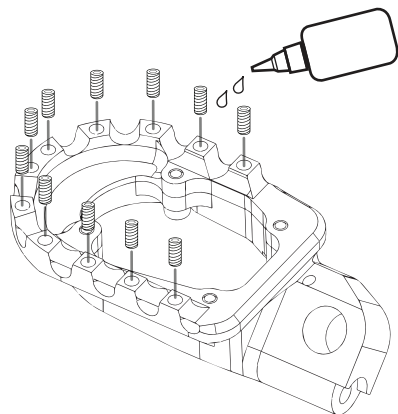

2.

Scegliere la posizione di montaggio (STANDARD o RIBASSATA) e inserire le bussole nelle pedane.
NOTA entrambe i tipi di bussola vanno inseriti nella pedana dalla parte inferiore.

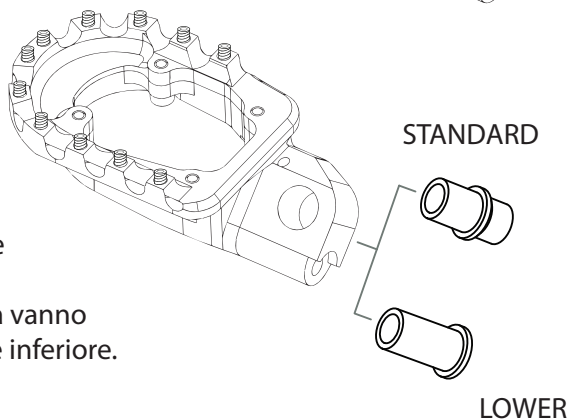

3.

Assemblare i rasamenti e la vite di fermo da M6 come in figura.
Utilizzare frenafilletti (Loctite 243).
Coppia di serraggio 16 Nm.

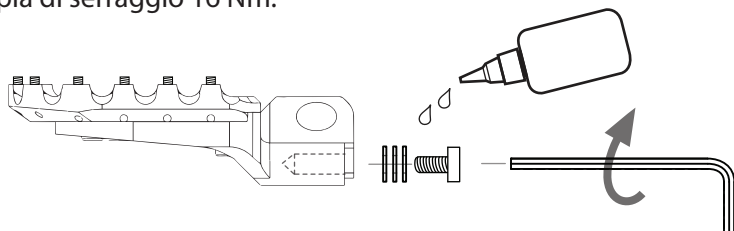

4.

Aggiungere o rimuovere rasamenti fino a raggiungere la posizione e l'inclinazione corretta.

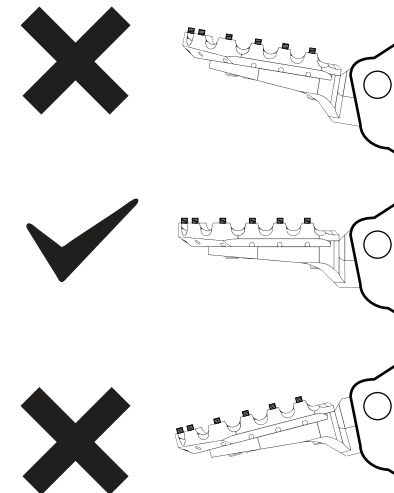

5.

Assemblare le molle sulle pedane nella posizione corretta. Destra e sinistra devono essere scambiate in base alla bussola scelta al punto 2. Inserire la punta della molla nel foro sull'attacco della pedana. Infine assemblare le pedane sulla moto.

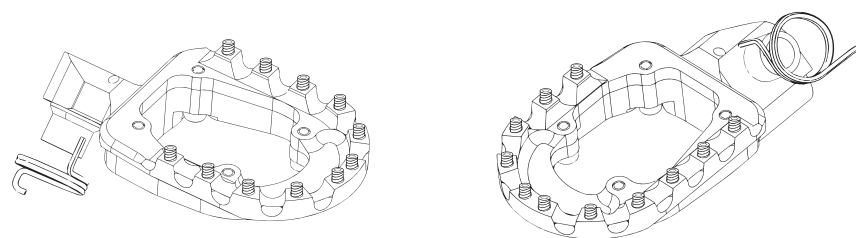

6.

I pad di alluminio possono essere sostituiti quando necessario rimuovendo le 4 viti inferiori da M4. Sostituendo i pad, assicurarsi che siano correttamente accoppiati al corpo in acciaio e sostituire il set di viti M4. Utilizzare frenafilletti (Loctite 243).

Produttore:
O.M. Costa Snc
fraz. Cervarolo
13019 Varallo Sesia
(Vercelli) Italia

MADE IN ITALY

Tutte le parti speciali CSP devono essere applicate esclusivamente a motocicli non destinati a circolare su strada, ma solo nell'ambito di competizioni e appositi campi gara.
L'assemblaggio deve essere eseguito da tecnici e/o professionisti del settore.
L'azienda produttrice non risponde dei danni causati dall'incorretto utilizzo dei propri prodotti.

STEEL-TECH FOOTPEGS

assembly instruction

CONSTRUCTION MATERIAL 39NiCrMo3 steel, alu. 7075 and stainless st.

MACHINING CNC turning and milling

SURFACE TREATMENT coloured anod. hox. and QPQ treatment



COSTA SPECIAL PARTS
info@costaspecialparts.it

1.

Assembly the M4 grub screws on the footpges.
Please use threadblocker (Loctite 243).
Locking torque 3,5 Nm.

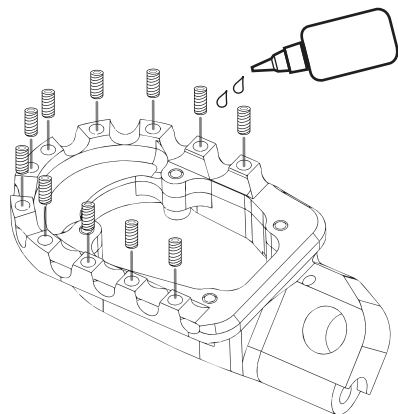

2.

Choose the mount position (STANDARD or LOWER) and insert the bushings in the footpges hole.
LOOK both bushing have to be fitted from low side of the footpeg.

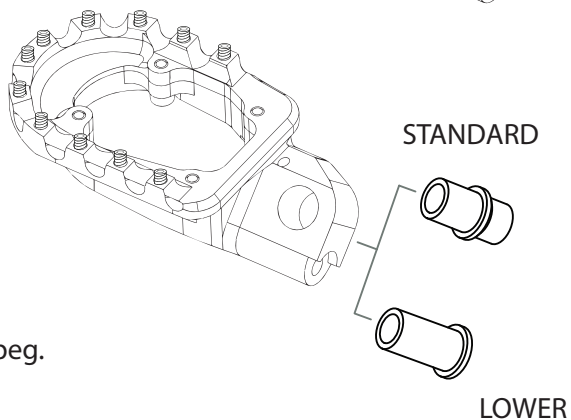

3.

Assembly the spacers and the M6 stop screws as in draw below.
Use threadblocker (Loctite 243).
Locking torque 16 Nm.

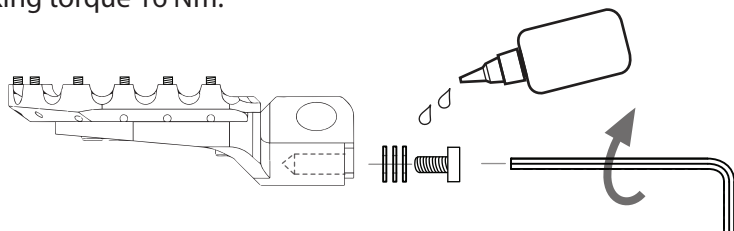

4.

Add or remove spacers to reach the correct position and inclination.

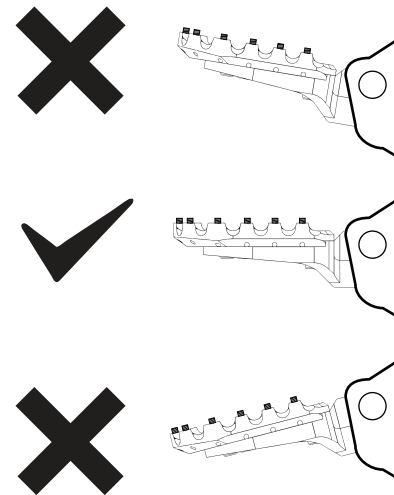

5.

Fit the springs in the correct position on the footpges.
They have to be swithced depending on the bushing you choose on step 2.
Insert the spring tip in the hole on the footpeg body.
Finally assembly the footpges on the bike.

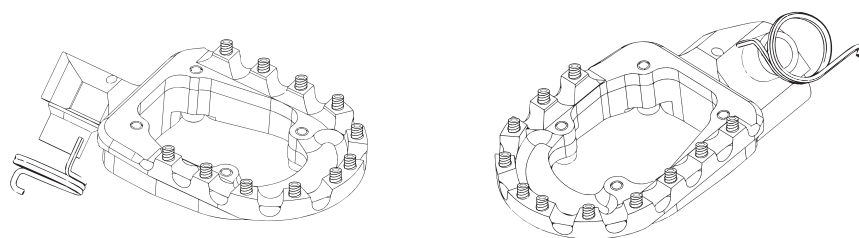

6.

The aluminum pads can be changed when needed by unscrewing the 4 lower M4 screws. When replacing pads, be sure they are correctly fitted on the steel body and replace the M4 screws with a new set.
Please use threadblocker (Loctite 243).

Manufacturer:
O.M. Costa Snc
fraz. Cervarolo
13019 Varallo Sesia
(Vercelli) Italia

MADE IN ITALY

*All CSP's special parts must only be applied to motorcycles non intended for road use, but only in competitions track and race fields.
The assembly must be performed by technicians or professionals. Manufacturer is not liable for damage caused by the incorrect use of its products.*